

38V Synchronous Buck Controller With 2CH CC/CV

❖ GENERAL DESCRIPTION

The MA5620 is a synchronous buck controller. The device need externals high side and external low side power MOSFETs, and provides 5A of continuous load current and a wide input voltage of 8V to 38V. Current mode control provides fast transient response and cycle-by-cycle current limit.

An internal soft-start prevents inrush current at turn-on, this device available in small TDFN-12L (3x3) package, provides a very compact solution with minimal external components.

❖ FEATURES

- Wide 8V to 38V Operating Input Range
- Externals high side and low side Power MOSFET Switches
- Output Adjustable from VFB(1.00V±2%) to 16V
- Up to 95% Efficiency
- Internal Soft-Start and Fixed 160KHz Frequency
- Duty on ratio : 0% to 91% PWM control
- Cycle-by-Cycle Over Current Protection
- Input Under/Over Voltage Lockout

❖ APPLICATION CIRCUIT

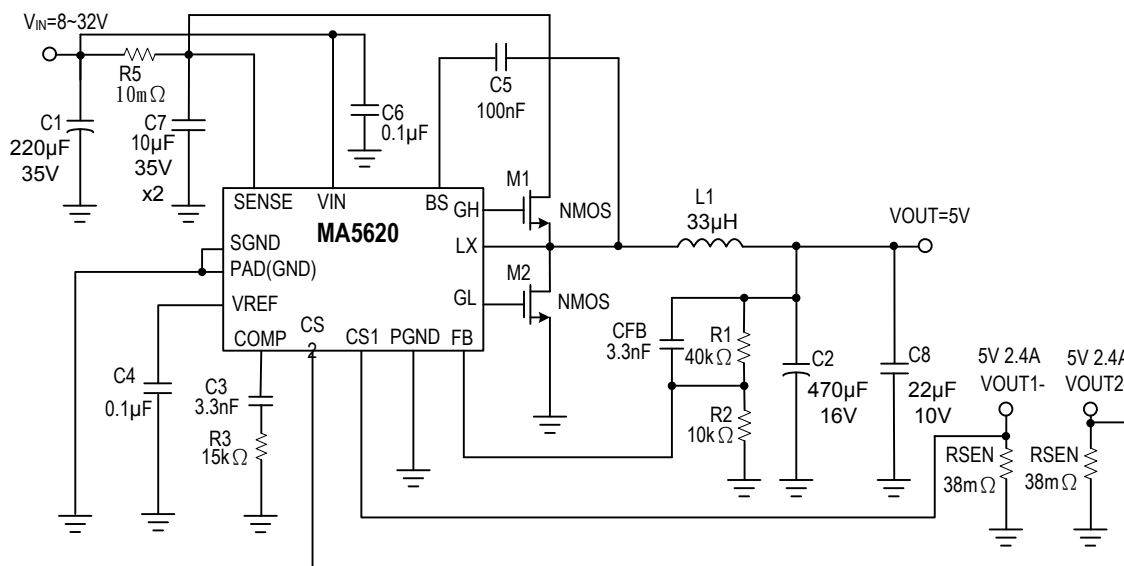

$$V_{OUT} = V_{FB} \times (1 + R1/R2), \quad V_{FB} = 1.00V, \quad R2 \text{ suggest } 1k \sim 30k\Omega$$

$$I_{SEN} = 2.63A \quad (I_{SEN} = V_{CS}(0.1V) / R_{SEN}(38m\Omega))$$

❖ PIN ASSIGNMENT

The package of MA5620 is TDFN-12L (3x3) package; the pin assignment is given by:

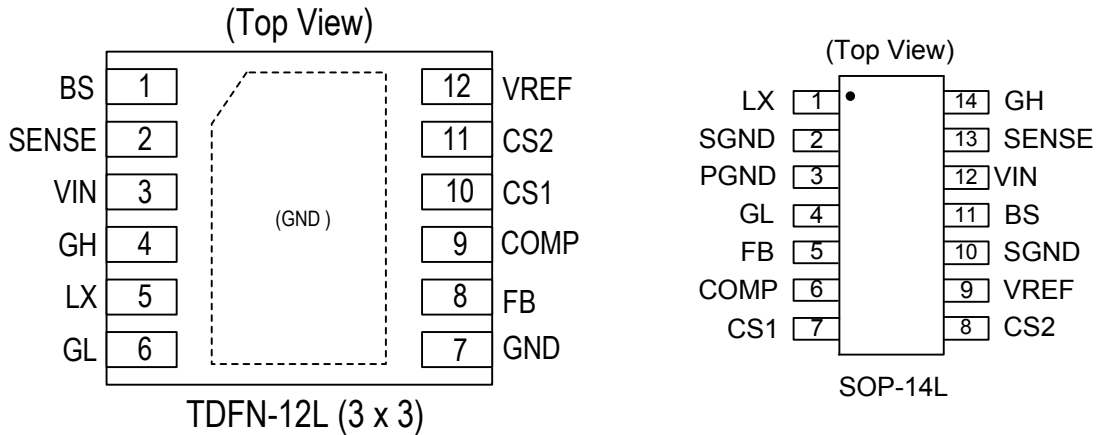

Name	Description
BS	Boot-Strap Pin. Supply high side gate driver. Decouple this pin to LX pin with 0.1uF ceramic cap.
SENSE	Power Input Current limit sense.
VIN	Power Input pin. Bypass IN to GND with a suitably large capacitor to eliminate noise on the input to the IC.
GH	Gate drive for external high side N-MOSFET..
LX	Switching sense.
GL	Gate drive for external low side N-MOSFET..
PGND/ GND	Power Ground.
FB	Feedback Input. FB senses the output voltage to regulate that voltage. Drive FB with a resistive voltage divider from the output voltage.
COMP	Compensation Node. COMP is used to compensate the regulation control loop. Connect a series RC network from COMP to GND to compensate the regulation control loop.
CS1	The Current Sense 1 pin.
CS2	The Current Sense 2 pin.
VREF	Internal regulator pin
PGND	Ground.
PAD	Ground (Connect to GND).

❖ ORDER/MARKING INFORMATION

Order Information	Top Marking
<p>MA5620XX X → Packing Blank: Tube A: Taping</p> <p>Package Type D3: TDFN-12L(3x3) S14: SOP14L</p>	<p>MA 5 6 2 0 → Part number</p> <p>X X X X X → ID code:internal → WW:01~52 → Year:16=2016</p>

❖ BLOCK DIAGRAM

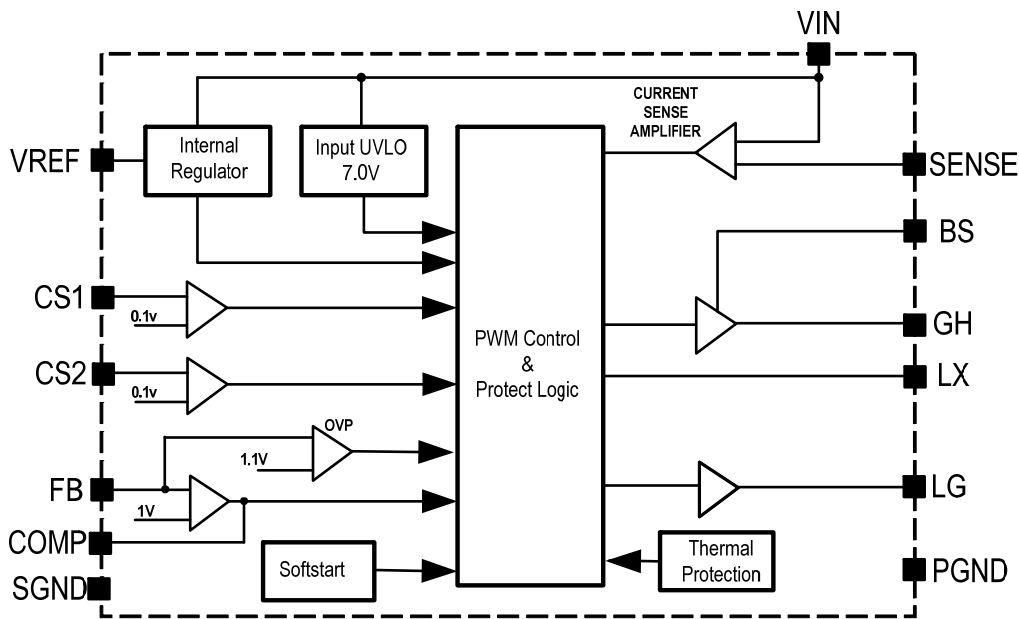

❖ ABSOLUTE MAXIMUM RATINGS (at $T_A=25^\circ\text{C}$)

Characteristics	Symbol	Rating	Unit
Supply Voltage	V_{IN}	-0.3 to +42	V
Switch Node Voltage	V_{SW}	-0.3 to $V_{IN} + 0.3$	V
Boost Voltage	V_{BS}	$V_{SW} - 0.3$ to $V_{SW} + 6$	V
All Other Pins		-0.3 to +6	V
Lead Temperature		260	$^\circ\text{C}$
Storage Temperature		-65 to +150	$^\circ\text{C}$
Junction Temperature	T_J	150	$^\circ\text{C}$
Output Voltage	V_{OUT}	VFB to 20	V
Ambient Operating Temperature		-40 to +85	$^\circ\text{C}$
Thermal Resistance from Junction to case	θ_{JC}	15	$^\circ\text{C/W}$
Thermal Resistance from Junction to ambient	θ_{JA}	40	$^\circ\text{C/W}$

Note: θ_{JA} is measured with the PCB copper area of approximately 1 in²(Multi-layer). That need connect to exposed pad.

❖ ELECTRICAL CHARACTERISTICS

($V_{IN} = 12V$, $T_A = +25^{\circ}C$, unless otherwise noted.)

Characteristics	Symbol	Conditions	Min	Typ	Max	Units
Input Voltage Range			8	-	38	V
Quiescent Current	I_{CCQ}	$V_{EN} = 5.0V$; $V_{FB} = 1.05V$	-	1	1.5	mA
Feedback Voltage	V_{FB}	$8V \leq V_{IN} \leq 38V$	0.98	1.00	1.02	V
Feedback Overvoltage Threshold	$OVP_{(FB)}$		-	1.1X	-	V_{FB}
Line compensation current(Note)	I_{CFB}	$V_{CS}=100mV$	-	4	-	μA
GH Rise Time	T_{GHR}	$C_{LX}=1200pF$	-	40	-	ns
GH Fall Time	T_{GHF}	$C_{LX}=1200pF$	-	40	-	ns
GL Rise Time	T_{GLR}	$C_{LX}=1200pF$	-	40	-	ns
GL Fall Time	T_{GLF}	$C_{LX}=1200pF$	-	40	-	ns
LG driver bias supply voltage			-	5	-	V
Oscillation Frequency	F_{OSC1}		-	160	-	KHz
Short Circuit Oscillation Frequency	F_{OSC2}	$V_{FB} = < 0.4V$	-	80	-	KHz
Short Circuit Retry time(Note)	RT_{SCP}	$V_{FB} = < 0.5V$	-	1	-	mS
Maximum Duty Cycle	D_{MAX}		-	91	-	%
Minimum On Time (Note)	$T_{ON(min)}$		-	220	-	ns
Current Sense Voltage	$V_{CS1/2}$		90	100	110	mV
EN Lockout Threshold Voltage	$ENH_{(LOCK)}$		-	2.5	-	V
EN Lockout Hysterisis			-	210	-	mV
Input Under Voltage Lockout Threshold	UVLO	V_{IN} Rising	6.5	7.0	7.5	V
Input Under Voltage Lockout Threshold Hysterisis	UVLO-Hys		-	800	-	mV
Input Over Voltage Lockout Threshold	OVLO	V_{IN} Rising	-	38	-	V
Input Over Voltage Lockout Threshold Hysterisis	OVLO-Hys		-	4	-	V
Soft-Start Period			-	3	-	ms
Thermal Shutdown	T_{SD}		-	150	-	$^{\circ}C$
Thermal Shutdown Hysterisis	T_{SH}		-	30	-	$^{\circ}C$

Note: Guaranteed by design.

❖ FUNCTION DESCRIPTIONS

The MA5620 is a synchronous rectified, current-mode step-down controller. It regulates input voltages from 8V to 38V down to an output voltage, and supplies up to 5A of load current.

The MA5620 uses current-mode control to regulate the output voltage. The output voltage is measured at FB through a resistive voltage divider and amplified through the internal Transconductance error amplifier. The voltage at the COMP pin is compared to the switch current measured internally to control the output voltage.

The controller uses external N-Channel MOSFET switches to step-down the input voltage to the regulated output voltage. Since the high side MOSFET requires a gate voltage greater than the input voltage, a boost capacitor connected between SW and BS is needed to drive the high side gate. The boost capacitor is charged from the internal 5V rail when SW is low.

When the MA5620 FB pin exceeds 10% of the nominal regulation voltage of VFB, the over voltage comparator is tripped and the COMP pin is discharged to GND, forcing the high-side switch off.

❖ APPLICATION INFORMATION

Setting the Output Voltage

The output voltage is set using a resistive voltage divider from the output voltage to FB pin. The voltage divider divides the output voltage down to the feedback voltage by the ratio. Thus the output voltage is:

$$V_{OUT} = V_{FB} \times \frac{R1 + R2}{R2}$$

For example, $V_{FB} = 1.00V$ for a 5.0V output voltage, R2 is 10kΩ, and R1 is 40kΩ.

Inductor Selection

The inductor is required to supply constant current to the output load while being driven by the switched input voltage. A larger value inductor will result in less ripple current that will result in lower output ripple voltage. However, the larger value inductor will have a larger physical size, higher series resistance, and/or lower saturation current. A good rule for determining the inductance to use is to allow the peak-to-peak ripple current in the inductor to be approximately 30% of the maximum switch current limit.

VIN	<28V	<35V
Inductor	33uH	33uH

The choice of which style inductor to use mainly depends on the price vs. size requirements and any EMI requirements.

Output Short-Circuit protection

The MA5620 provides output short-circuit protection retry function. When V_{OUT} is short (V_{FB}<0.5V), the auto restart function can be started that restart the regulator cycle by cycle. (Retry time 1mS , Shutdown regulator time 20mS) .

Output Cable Resistance Compensation

To compensate for resistive voltage drop across the charger's output cable, the MA5620 integrates a simple, user-programmable cable voltage drop compensation using the impedance at the FB pin. Use the curve in Figure 1 to choose the proper feedback resistance values for cable compensation. R1 is the high side resistor of voltage divider.

$$V_{OUT} = V_{FB} \times (1 + R1/R2) + R1 \times I_{FB}(4\mu A)$$

❖ TYPICAL CHARACTERISTICS

1. TDFN3x3-12L

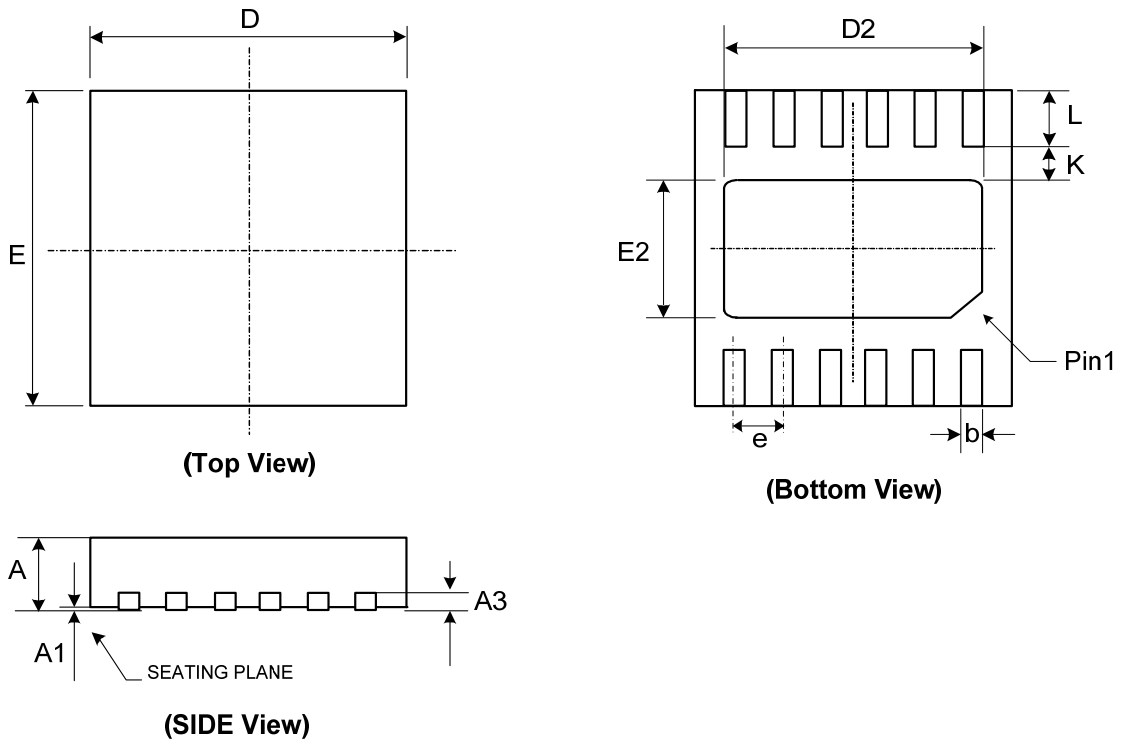

Symbol	Dimensions in Millimeters			Dimensions in Inches		
	Min.	Nom.	Max.	Min.	Nom.	Max.
A	0.70	0.75	0.80	0.028	0.030	0.031
A1	0.00	0.02	0.05	0.000	0.001	0.002
A3	0.20 REF			0.008 REF		
b	0.18	0.25	0.28	0.008	0.010	0.011
D	3.00 BSC			0.118 BSC		
D2	2.40	2.50	2.55	0.094	0.098	0.100
E	3.00 BSC			0.118 BSC		
E2	1.50	1.60	1.65	0.059	0.063	0.065
e	0.45 BSC			0.018 BSC		
L	0.30	0.40	0.50	0.012	0.016	0.002
K	0.20	-	-	0.008	-	-

2. SOP14

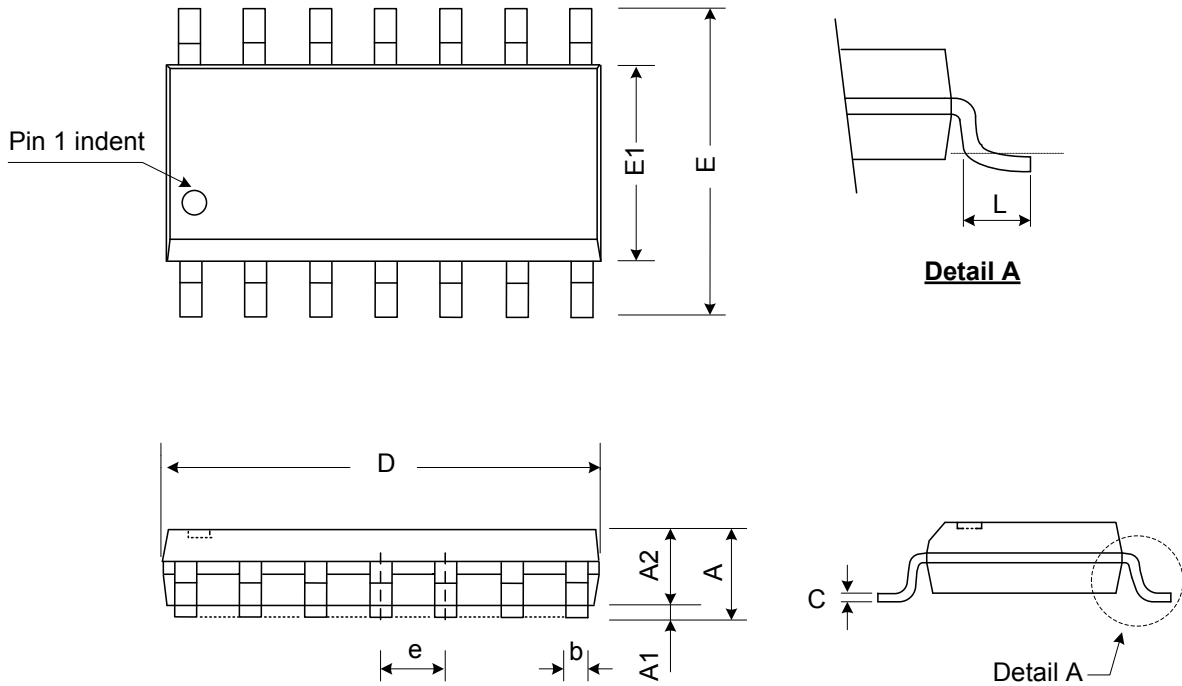

Symbol	Dimensions In Millimeters			Dimensions In Inches		
	Min.	Nom.	Max.	Min.	Nom.	Max.
A	1.47	1.60	1.730	0.0580	0.063	0.0680
A1	0.10	-	0.250	0.0040	-	0.0100
A2	-	1.45	-	-	0.057	-
b	0.33	0.41	0.510	0.0130	0.016	0.0200
C	0.19	0.20	0.250	0.0075	0.008	0.0098
D	8.53	8.64	8.740	0.3360	0.340	0.3440
E	5.80	6.00	6.200	0.2283	0.236	0.2441
E1	3.80	3.90	3.990	0.1496	0.153	0.1571
e	-	1.27	-	-	0.050	-
L	0.38	0.71	1.270	0.0150	0.028	0.0500